

SUITABLE TRAILER BUNKS FOR SAIL MFG BOATS

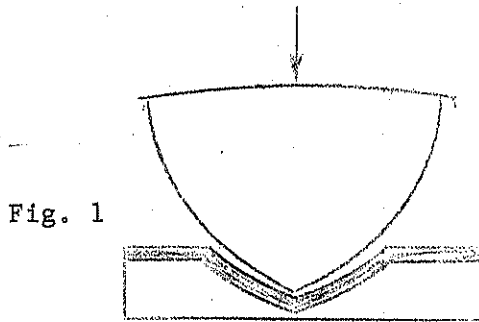

Fig. 1

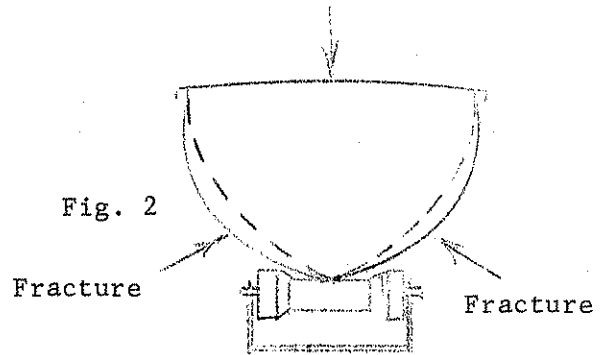

Fig. 2

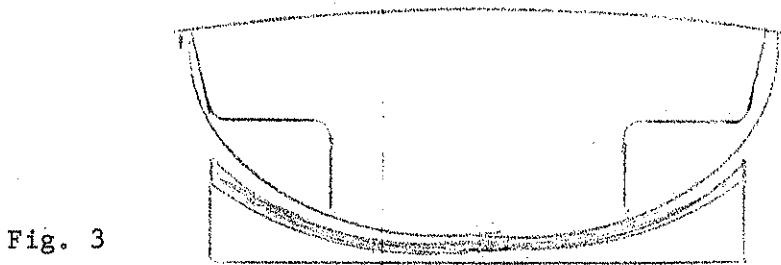

Fig. 3

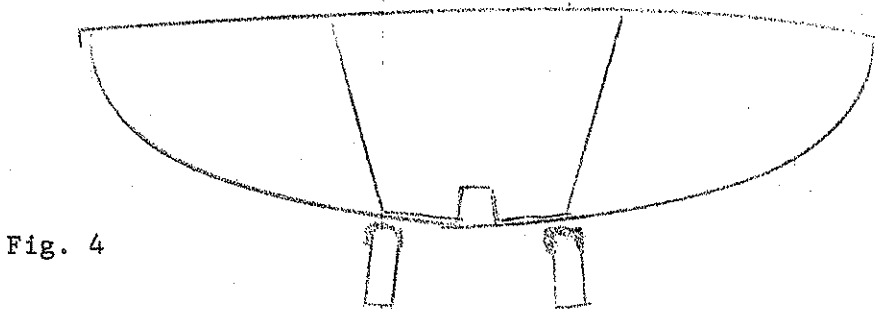

Fig. 4

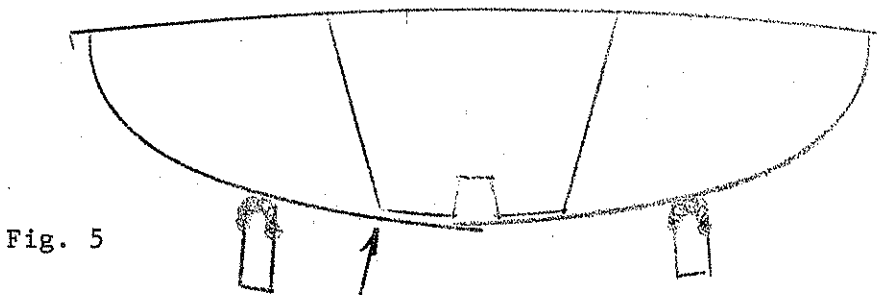

Fig. 5

Fracture

Fig. 1. Adequate support for Catamaran using a fitted cradle.

Fig. 2. A trailer with rollers only will result in fractures at the turn of the bilge.

Fig. 3. Typical support for Pintail, Copperhead, or Sidewinder other round hulls.

Fig. 4. Suitable support for Copperhead and Sidewinder placing longitudinal support at the vertical inner cockpit wall.

Fig. 5. Most boat trailers with longitudinal supports are too wide. This arrangement will result in fractures as indicated (as will rolling the boat on it's side if full of water).